

The MAX horizontal multistage centrifugal pumps combine the functional benefits of centrifugal pumps and the practical benefits of self priming pumps. They warrant high hydraulic and suction performances.

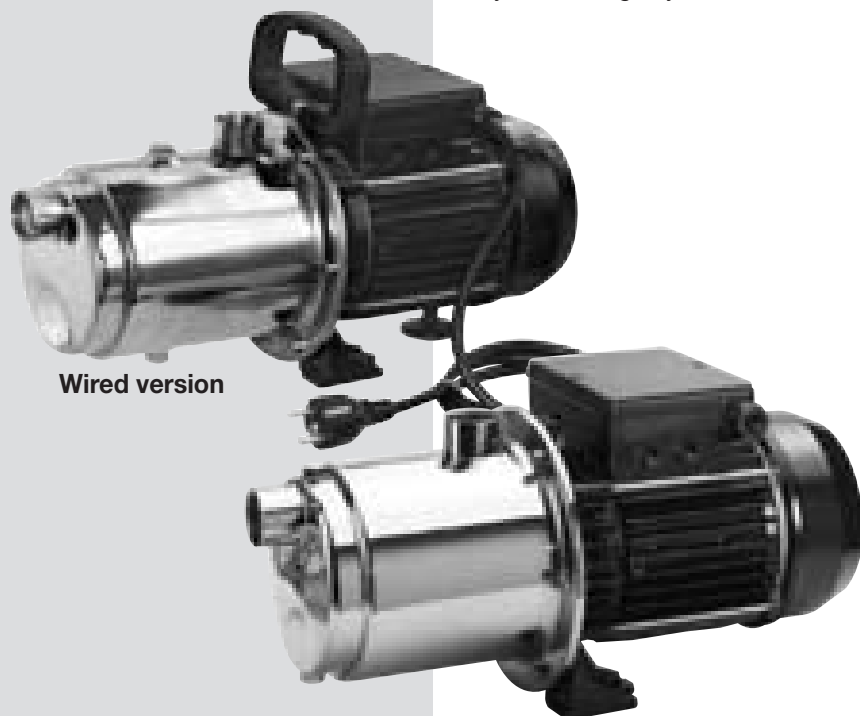

Wired version

Applications

- Pumping and distribution of water in domestic systems
- Booster systems
- Firefighting systems
- Washing systems, irrigation

Usage limitations

- Type of liquid: clean water with no suspended solids or abrasive material
- Maximum liquid temperature 50°C
- Maximum recommended suction height 7m with foot valve
- Maximum operating pressure 7 bar

Motor

- Enclosed, externally ventilated
- Level of protection IP 44
- Class F insulation
- Single phase power supply with capacitor permanently activated and thermal protection built into the motor winding
- Three phase power supply with external protection provided by the user
- Speed of rotation 2850 rpm
- Suitable for continuous use

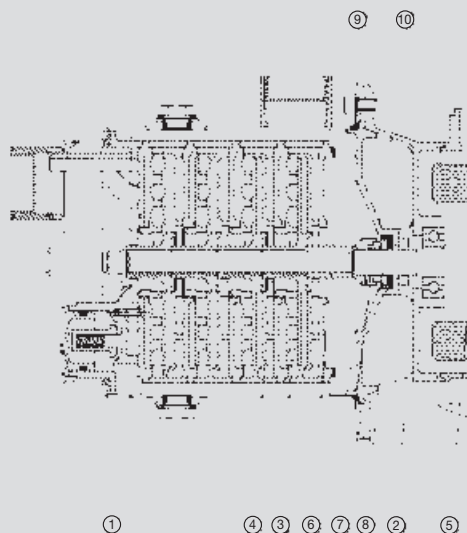

DESIGN FEATURES

Component	Material
1 Pump casing	X5 CrNi 1810 (AISI 304) Stainless steel
2 Motor bracket	Die-cast aluminium
3 Impeller	Technopolymer with X5 CrNi 1810 (Aisi 304) Stainless steel shim ring
4 Diffusors	Technopolymer
5 Shaft (hydraulic end)	X5 CrNi 1810 (AISI 304) Stainless steel
6 Spacer	OT 58 Nickel plated brass
7 Mechanical seal	Graphite
8 Counterface	Ceramic
9 O'ring	NBR 70 Shore
10 Seal holder plate	GFN2V Noryl

TABLE OF HYDRAULIC PERFORMANCE

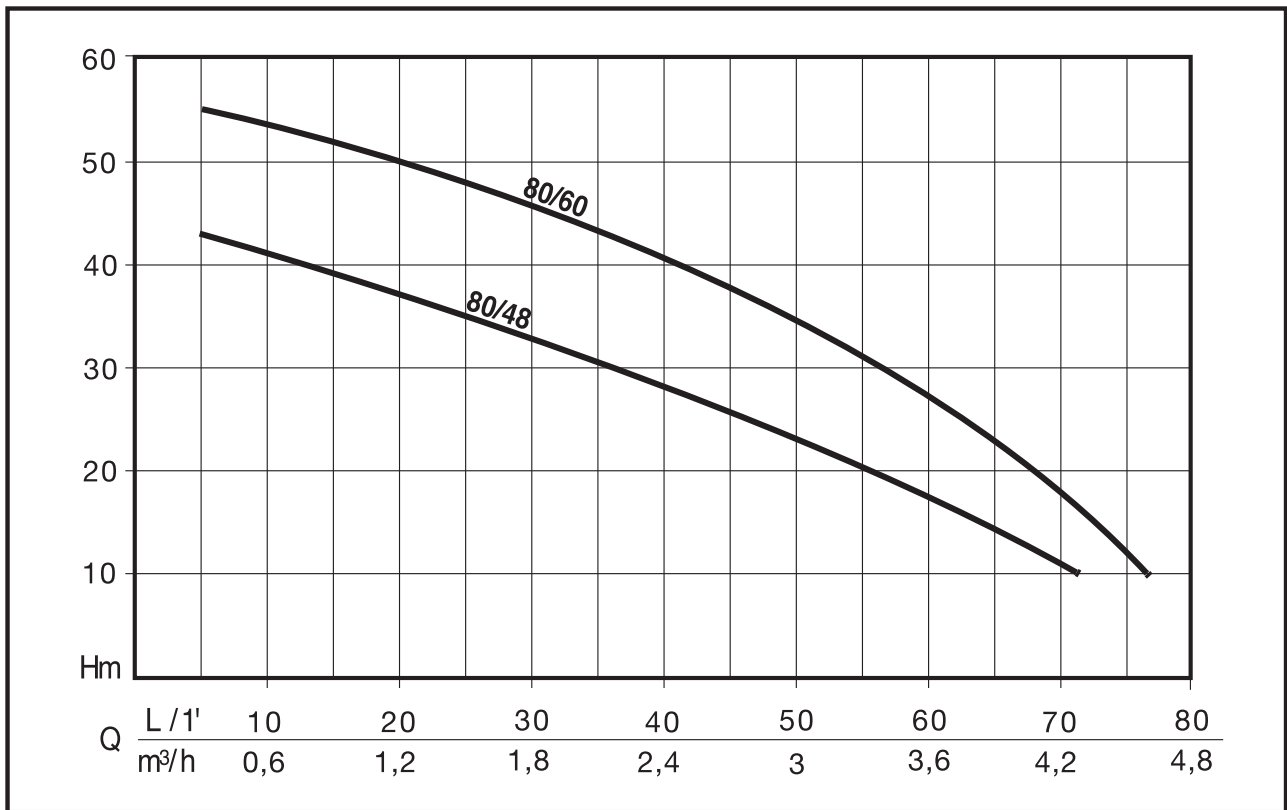

PUMP PERFORMANCE

CODE	MODEL	Nominal Power		Absorbed Power		VOLTAGE (V)	Amp.	μF.	Discharge head in meters	L/1'	0	20	40	60	80
		HP	kW	HP	kW					Q	0	1,2	2,4	3,6	4,8
N4501030-B	MAX 80/48 M	0,75	0,55	1,1	0,8	1 ~ 230 V	4	12,5		45	36	28	17	1	
N4501070-B	MAX 80/48 T					3 ~ 230 ÷ 400 V	2,6-1,5								
N4501220	MAX 80/48 C*					1 ~ 230 V	4								
N4501040-B	MAX 80/60 M	1	0,75	1,3	1	1 ~ 230 V	4,8	16		57	50	40	27	3	
N4501080-B	MAX 80/60 T					3 ~ 230 ÷ 400 V	2,9-1,7								

* Version equipped with cable, schuko plug, handle and switch

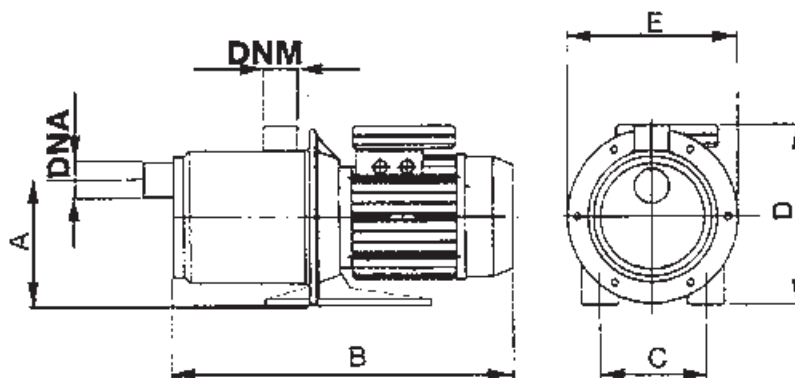
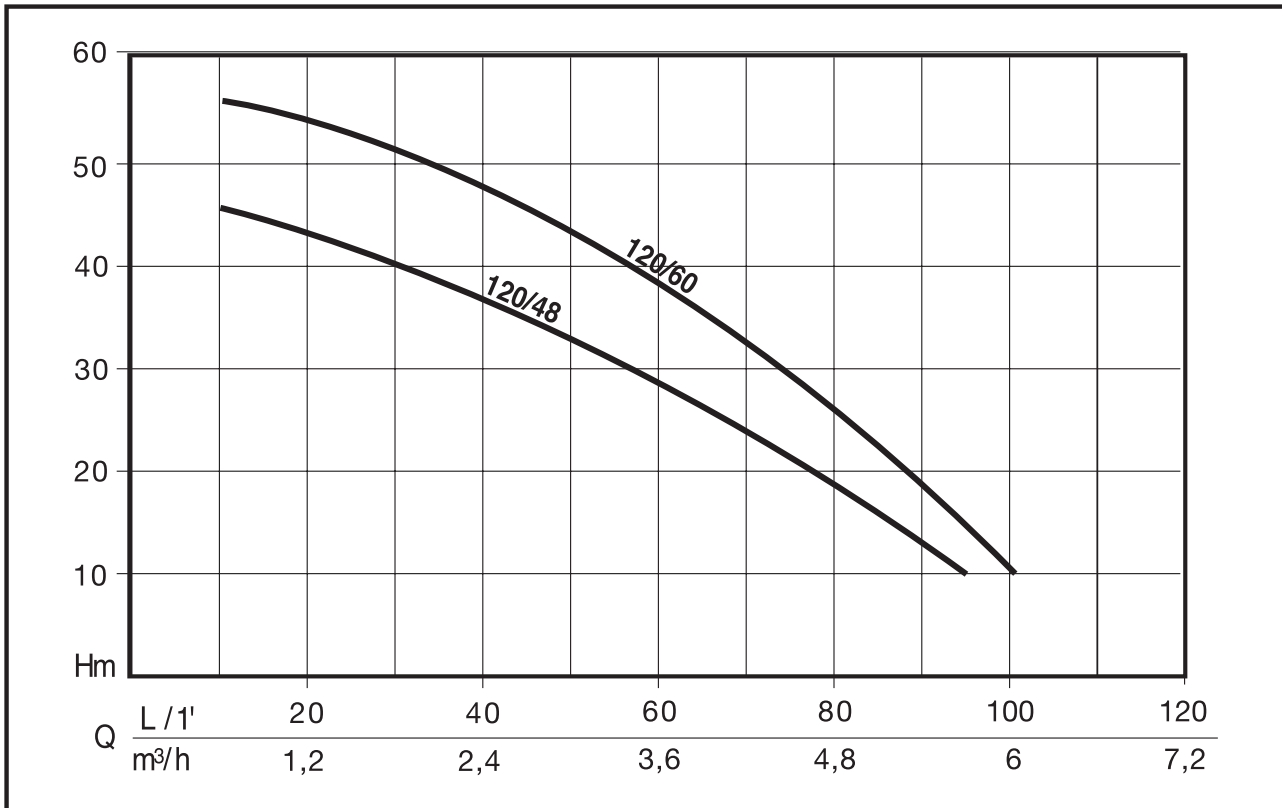

TABLE OF SIZES AND WEIGHTS

Model	Dimensions mm.							Weight
	A	B	C	D	E	DNA	DNM	kg
MAX 80/48	129	370	99	182	176	1"	1"	8
MAX 80/60	129	392	99	182	176	1"	1"	9

TABLE OF HYDRAULIC PERFORMANCE



PUMP PERFORMANCE

CODE	MODEL	Nominal Power		Absorbed Power		VOLTAGE (V)	Amp.	μF.	Q	Discharge head in meters					
		HP	kW	HP	kW					L/1'	0	20	40	60	80
N4501050-B	MAX 120/48 M	1	0,75	1,5	1,1	1 ~ 230 V	4,6	16	48	42	37	27	18	5	
N4501090-B	MAX 120/48 T					3 ~ 230 ÷ 400 V	3,6-2,1								
N4501060-B	MAX 120/60 M	1,2	0,9	1,7	1,25	1 ~ 230 V	5,8	20	60	55	48	36	26	10	
N4501100-B	MAX 120/60 T					3 ~ 230 ÷ 400 V	3,5-2								
N4501190-B	MAX 120/60 C*					1 ~ 230 V	5,8								

* Version equipped with cable, schuko plug, handle and switch

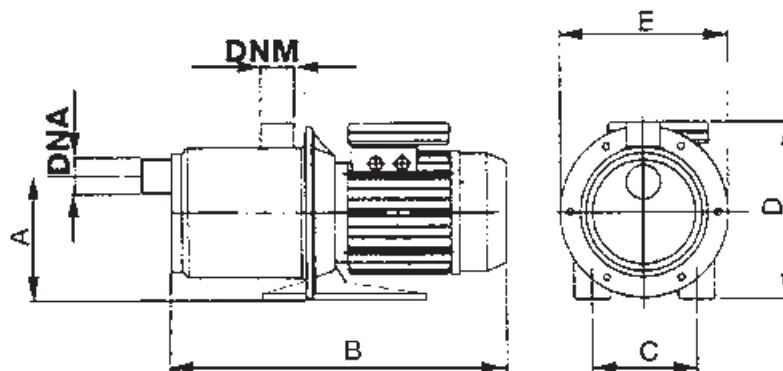

TABLE OF SIZES AND WEIGHTS

Model	Dimensions mm.							Weight kg
	A	B	C	D	E	DNA	DNM	
MAX 120/48	129	393	99	192	176	1"	1"	10
MAX 120/60	129	392	99	182	176	1"	1"	11